

# Wheel Loader Pallet Fork

**Load Guard** protects the machine from contact with heavy pallet loads to prevent damage.

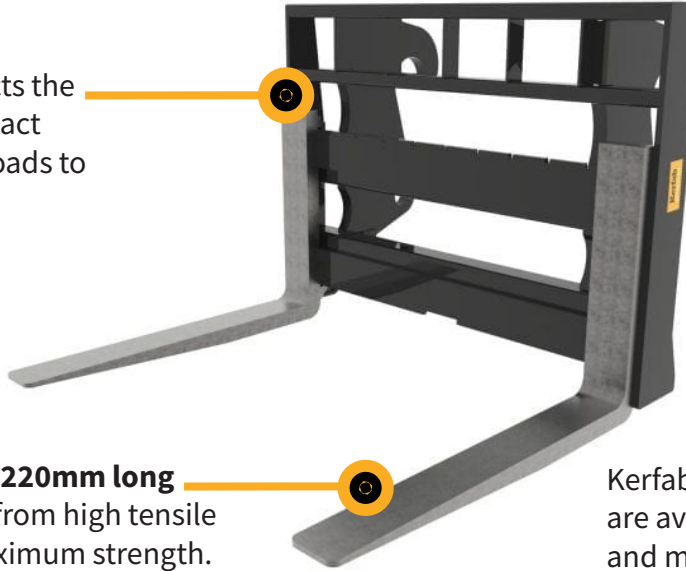

**1070mm - 1220mm long** tines made from high tensile steel for maximum strength.

Kerfab's range of Wheel Loader Pallet Forks are available in a range of widths, capacities and machine sizes. Below is a list of our most popular sizes. **Custom Solutions Available**

## Product Specs

### Fast Facts

- + 12 Month Manufacturers Warranty
- + Customisable to exact specifications
- + Variable tine sizes depending on application

### About

- + Designed specifically for wheel loaders, this attachment can be custom built to suit any application.
- + Easily lifts pallets, logs, pipes, general freight and fruit bins with a single machine.
- + Kerfab's line-up of different sizes, offers lifting capacities ranging from 1500kg to 8000kg with different tine lengths, ensuring that you will find a model to suit your specific needs.
- + A quick hitch is the ideal companion for a wheel loader with a pallet fork. It allows the machine to quickly switch between the fork and any other attachment.
- + High-quality hydraulic fittings and hoses are fitted when side shifts or load guard positioners are added to the fork frame (can be fitted with side shift fork positioners as an options).

Part Number	Width (mm)	Weight (kg)	Tine Length (mm)
LCLP15	1200	195	1070
LCLP25	1200	210	1070
LCLP30	1200	380	1070
LCLP40	1200	410	1070
LCLP50	1600	430	1220
LCLP60	1600	600	1220
LCLP70	1600	735	1220
LCLP80	1600	830	1220
LAPF15	1200	195	1070
LAPF25	1200	210	1070
LAPF30	1200	380	1070
LAPF40	1200	410	1070
LAPF50	1600	430	1220
LAPF60	1600	600	1220
LAPF70	1600	735	1220
LAPF80	1600	830	1220

# Backrest Designs

## Clearview Backrest

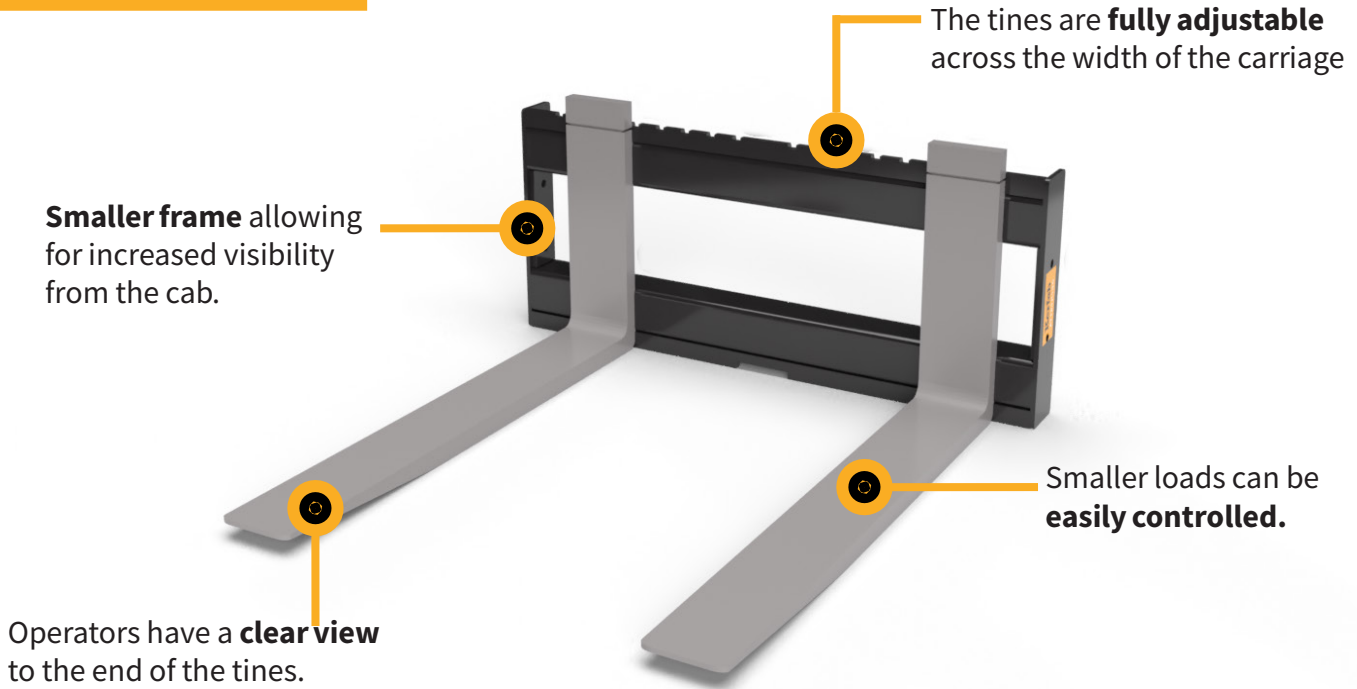

## Loadguard Backrest

