

# Operation Manual

## Cotton Forks



Dear valued customer, we kindly ask that you carefully review the operating manual for your product and complete the product registration process to ensure that you are eligible for warranty coverage. Thank you for taking the time to follow these important steps to protect your investment.



+ 1800 818 079

+ [kerfab.com.au](http://kerfab.com.au)

+ [sales@kerfab.com](mailto:sales@kerfab.com)

**Kerfab**  
ATTACH+GO

# CONTENTS

|                                    |           |
|------------------------------------|-----------|
| <b>INTRODUCTION</b>                | <b>2</b>  |
| <b>OWNER INFORMATION</b>           | <b>2</b>  |
| <b>GENERAL INFORMATION</b>         | <b>3</b>  |
| <b>PLANT ASSESSMENT</b>            | <b>4</b>  |
| <b>COTTON FORK FEATURES</b>        | <b>4</b>  |
| <b>RISK ASSESSMENT AND CONTROL</b> | <b>5</b>  |
| <b>WORKSITE SAFETY</b>             | <b>6</b>  |
| <b>MAINTENANCE</b>                 | <b>6</b>  |
| <b>SPARE PARTS</b>                 | <b>7</b>  |
| <b>OPERATING INSTRUCTIONS</b>      | <b>8</b>  |
| <b>PRODUCT REGISTRATION</b>        | <b>12</b> |
| <b>KERFAB WARRANTY STATEMENT</b>   | <b>13</b> |





## INTRODUCTION

Kerfab is a specialist manufacturer of a comprehensive range of attachments covering a wide spectrum of market sectors. The cotton forks you have purchased is just one of a vast range of purpose-built products available in our range. Each attachment is engineered to relevant codes and standards along with input from experienced team which in turn provides you with an optimum item which will provide you with many years of service.

## OWNER INFORMATION

Thank you for choosing to purchase a Cotton Fork from Kerfab. To ensure maximum performance, it is mandatory that you study this operation manual to ensure your equipment continues to operate to maximum performance. Proper operation and maintenance are essential to prevent injury or damage and to maximise attachment life.

Continuous improvement is at the forefront of the Kerfab culture meaning that changes in product design may not be reflected in this document. Great care has been taken in preparing this document with accuracy however Kerfab does not assume any liability for errors or omissions.

|   |   |
|---|---|
|  | Potentially Fatal Danger                    |
|  | Risk of Serious Injury                      |
|  | Risk of Material Damage and/or Minor Injury |
|  | Maintenance operation or Information        |

## GENERAL INFORMATION

This operation manual was written to provide the owner/ operator instructions on the safe operation and maintenance of the Cotton Fork Attachment.

PLEASE READ AND UNDERSTAND THE OPERATION AND MAINTENANCE OF YOUR COTTON FORK BEFORE OPERATING YOU KERFAB ATTACHMENT.

Kerfab Cotton Forks are used on Wheel Loaders, Telehandlers and Agricultural Tractors therefore this manual is a permanent part of your machine.

### Attachment Inspection

All delivered products by Kerfab should be initially checked for any defects, damages or missing parts to ensure performance of attachment upon taking delivery of item.



Please notify Kerfab with a report of any problems within 10 business days.

### Vital Point

Please keep this manual with the Machine once the attachment has been installed on the machine. The Operator should have a full understanding of full use of this attachment before use.

### Attachment Features

The Kerfab Cotton Fork makes light work of lifting and transporting single large round cotton bales. Tines spear the flat surface of the bale and prevent damage to the wrapping. Both 3 and 5 tine designs have the same back frame height of 1.05m for better customisation to suit your needs. No moving parts or hydraulic power is needed therefore it is quicker and simpler operate

## Plant Assessment

**NB. This Plant Assessment ONLY applies to the attachment named below. It DOES NOT extend to other item(s) of plant that are used to operate this attachment**







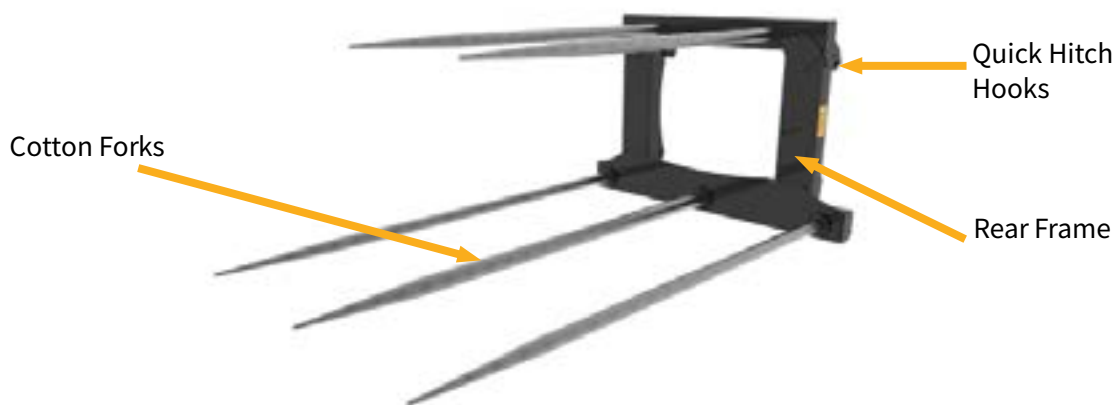





|                            |  |
|----------------------------|--|
| <b>Plant Type:</b>         | <b>Cotton Forks</b>  |
| <b>Specifications:</b>     | Refer to the Identification Plate on the Cotton Fork for the specifications relevant to this attachment. The loads carried by the Cotton Fork should NEVER EXCEED THE LOAD LIMIT OF THE COTTON FORK OR THE LOAD LIMIT OF THE MOBILE PLANT it is attached to eg. Ag loader, wheel loader, telehandler, in the full scope of each mobile plant's operations. |
| <b>Description of Use:</b> | The Cotton Fork is designed for lifting cotton bales on front end loaders, telehandlers, and wheel loaders. It is designed to lift the bales with minimal stretching of the wrap. NB: This attachment is to be only used for the purpose for which it is designed and intended   |







## Cotton Fork Features



**Risk Assessment and Control**

| Symbol   | Risk   | Control   |
|--|--|---|
|       | <p>Body parts can be crushed between the mobile plant and Cotton Fork attachment points when connecting Cotton Fork to the mobile plant mount.</p> | <p>Keep hands and body parts clear of the area between the Cotton Fork attachment point and mobile plant mount.</p>   |
|       | <p>Fingers may be jammed in locking pinpoints as locking pins are engaged.</p>   | <p>Keep fingers clear when engaging locking pins into locking pinpoints at the rear of Cotton Fork.</p>   |
|   | <p>Fingers and hands can be crushed or pinched when adjusting the rear frame up or down.</p>   | <p>Keep hands clear of the frame as the rear frame is adjusted up and down</p>  |
|   | <p>Body parts can be crushed if Cotton Fork unexpectedly releases from the mobile plant mount</p>  | <p>Ensure Cotton Fork is securely attached prior to use including fully engaging lower pins. · Regularly check that hitch points on Cotton Fork and also mobile plant mount</p> |
|   | <p>Body parts can be crushed by unexpected tipping of Cotton Fork</p>  | <p>Ensure Cotton Fork is stable when released from the mobile plant mount.</p>  |
|   | <p>Body parts can be crushed by unexpected release or movement of load.</p>  | <p>Ensure bales are balanced to avoid sudden movement when lifted. Regularly check Cotton Fork for damaged or bent/distorted parts and damaged welds</p>                        |

| <h2 style="margin: 0;">Worksite Safety</h2>  |   |
|---|---|
|   | <ul style="list-style-type: none"> <li>All people involved in the operation are to wear appropriate personal protective equipment which may include eye protection, hearing protection, gloves, protective footwear, and high visibility clothing/vests.</li> </ul> |
|   | <ul style="list-style-type: none"> <li>Cotton Fork should be operated by a trained and experienced operator or an operator under direct supervision.</li> </ul>   |
|   | <ul style="list-style-type: none"> <li>People to <b>NOT</b> enter the work area or sweep the area of attachment and load unless under the direction of the operator.</li> </ul>   |
|   | <ul style="list-style-type: none"> <li><b>NEVER</b> walk under the Cotton Fork or load.</li> </ul>  |
|   | <ul style="list-style-type: none"> <li><b>NEVER</b> elevate Cotton Fork or load above or in proximity to people.</li> </ul>   |
|   | <ul style="list-style-type: none"> <li>Ensure all persons are clear of Cotton Fork when it is being hitched or re-released.</li> </ul>  |
|   | <ul style="list-style-type: none"> <li>Ensure bales are secure and stable prior to release from Cotton Fork to avoid bales moving after release.</li> </ul>   |

| <h2 style="margin: 0;">Maintenance</h2>   |  |   |
|---|--|---|
|   | Check hitch points and locking bolts for wear and damage.                      |  |
|   | Check all welds for damage or cracks.  |  |
|   | Check tines for wear and distortion.   |  |
|   | Check the rear frame and securing pins for wear, damage, or bends/distortions. |  |
| <p><b>DO NOT USE COTTON FORKS IF WEAR OR DAMAGE MAKES THE USE OF THE COTTON FORKS HAZARDOUS</b></p> |  |   |

## SPARE PARTS

### Bale Fork Tine Sizes:

| Length       |
|--------------|
| Ø60mm 2010mm |
| Ø60mm 2460mm |
| Ø75mm 2460mm |

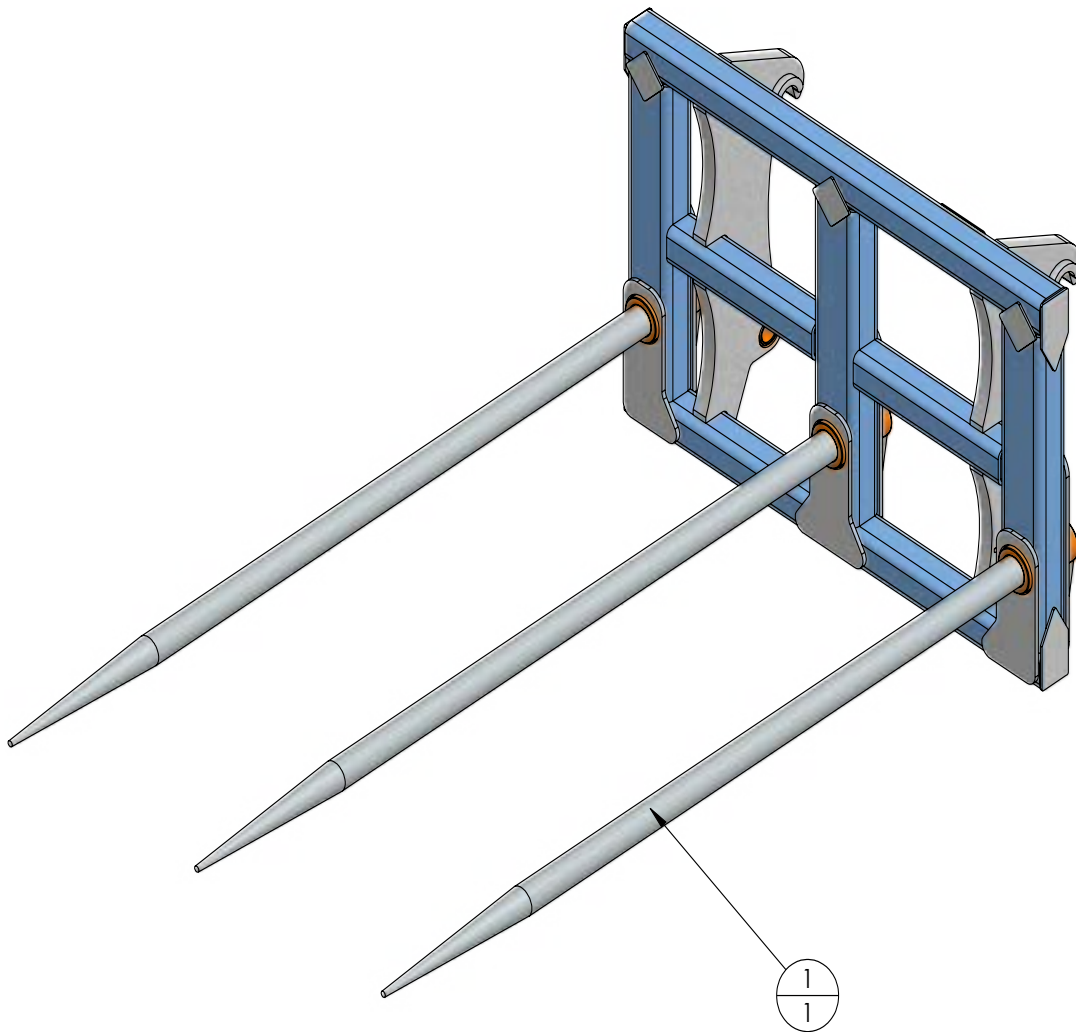

| NO. | DESCRIPTION      | QTY |
|-----|------------------|-----|
| 1   | COTTON BALE FORK | 1   |

## **OPERATING INSTRUCTIONS**

### **ENGAGING IMPLEMENT STEPS**

#### **STEP 1**

Approach the cotton forks with top pick-up bar in sight and aligned with quick hitch hooks.

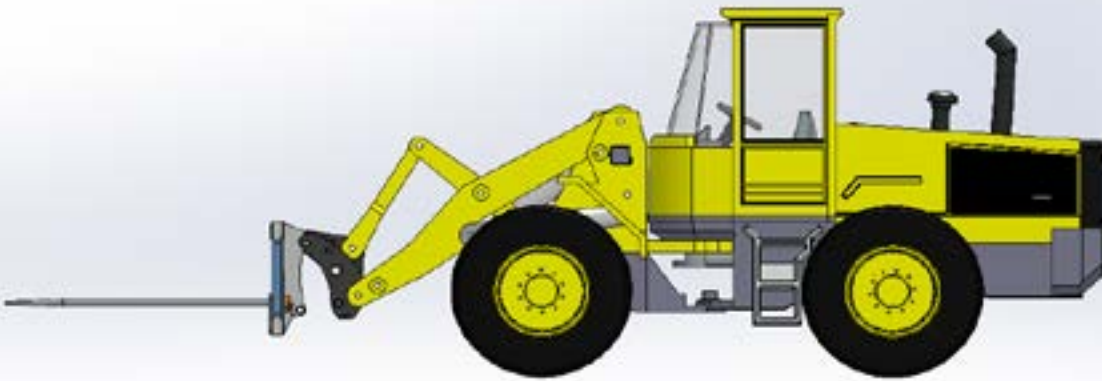

#### **STEP 2**

Engage top bar with hook by raising loader arms. Roll the cotton forks back to ensure hook stopper is resting against the coupler. Engage quick coupler locking pins.

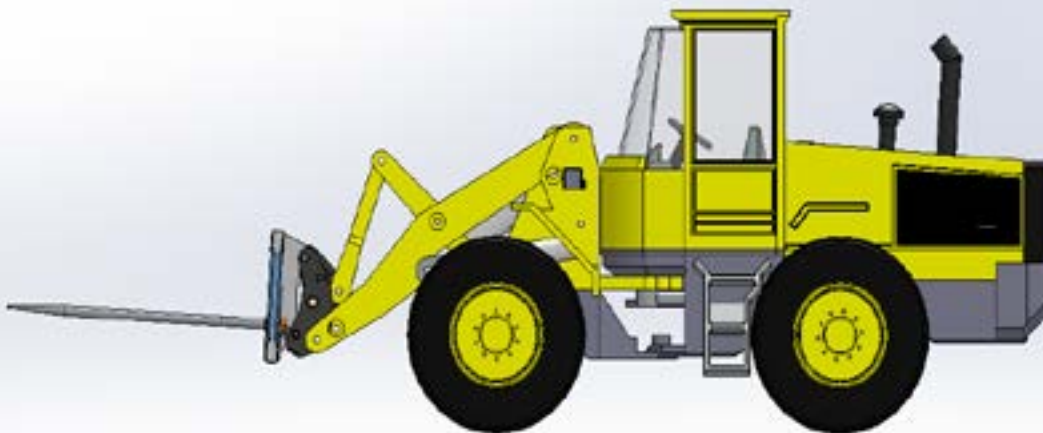

**STEP 3**

Check that locking pins are engaged by view indicators. Note: Models with no indicators will require a physical check by the operator

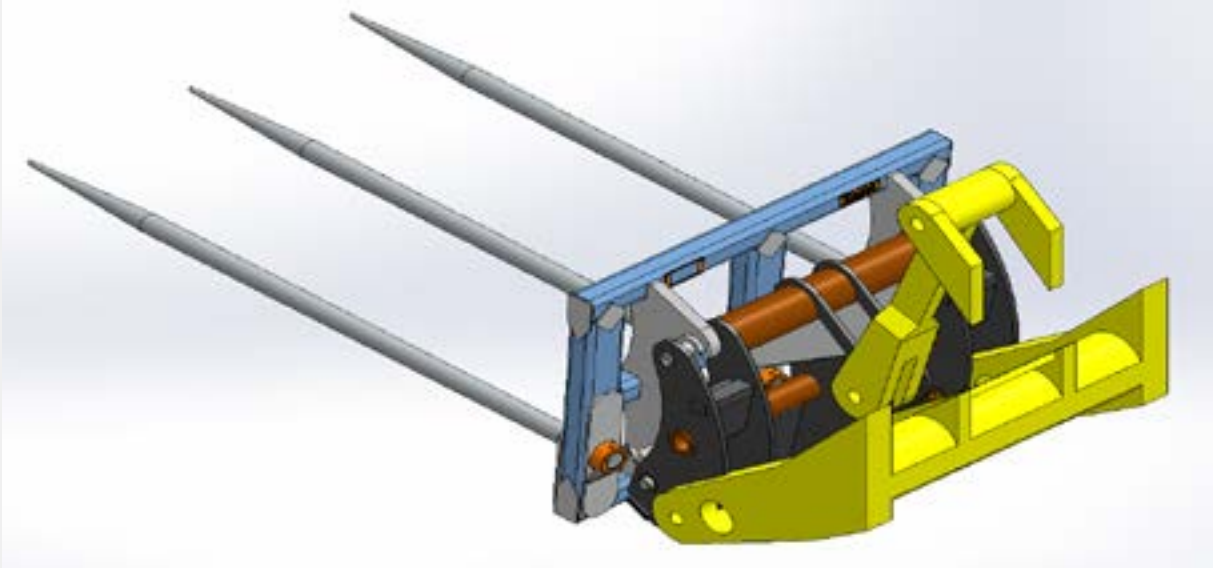
**DISENGAGING IMPLEMENT STEPS****STEP 1**

Slightly roll back implement to ensure hook bump stops are resting against the quick coupler. Disengage locking pins.



**STEP 2**

Check that locking pins are disengaged. Note: Models without indicators may need a physical check by the operator.

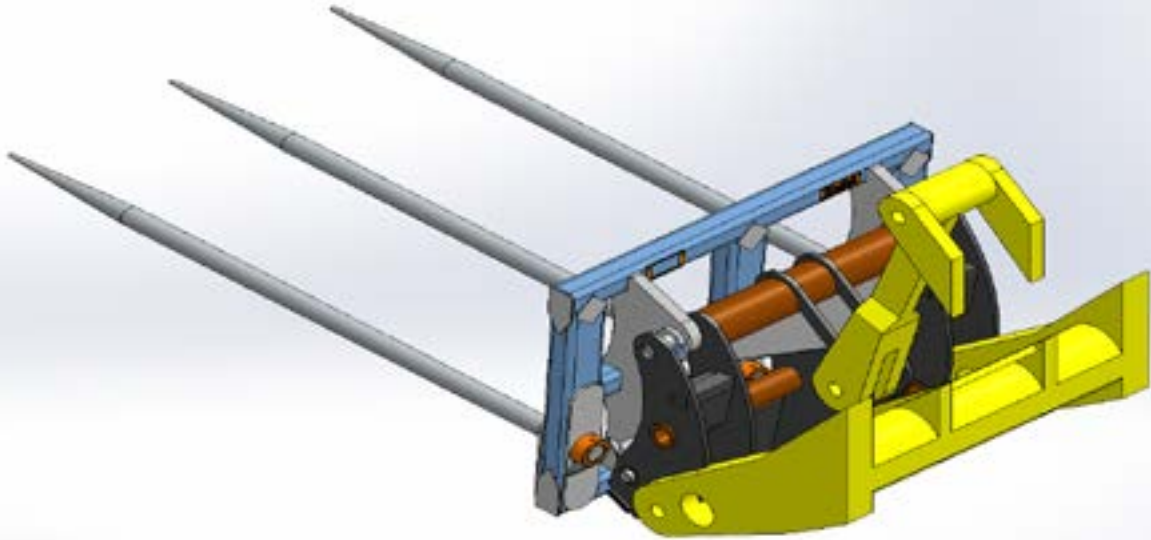
**STEP 3**

Slightly roll coupler forward to rest front of the cotton forks on the ground as shown.

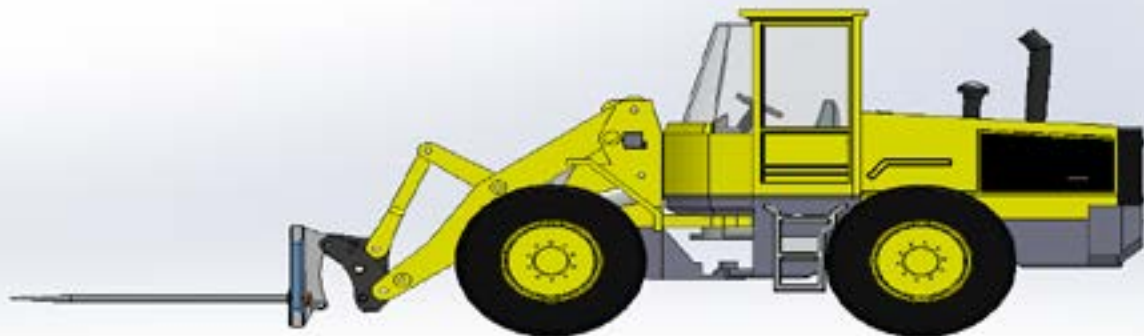

**STEP 4**

Lower loader arms until top pick-up bar becomes disengaged from quick coupler hooks

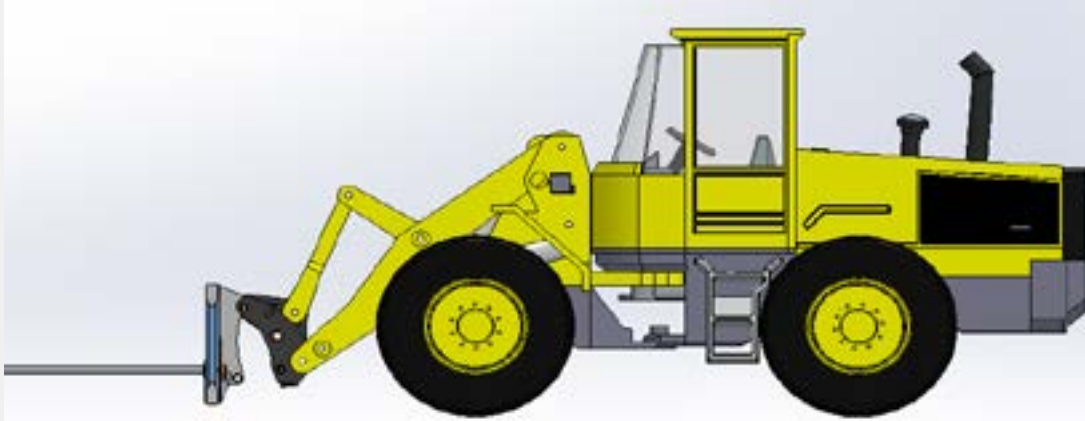

**WARNING: NEVER ROLL COUPLER OVER AS SHOWN BEFORE DISENGAGING. \*This will cause damage to attachment\***

**STEP 5**

Reverse away from the cotton forks.



## Product Registration

|                            |  |
|----------------------------|--|
| <b>Date of Delivery:</b>   |  |
| <b>Name:</b>               |  |
| <b>Company:</b>            |  |
| <b>Street Address:</b>     |  |
| <b>Phone Number:</b>       |  |
| <b>E-mail Address:</b>     |  |
| <b>Model Number:</b>       |  |
| <b>Serial Number:</b>      |  |
| <b>Sales Order Number:</b> |  |

I confirm that the operator has read and understands the Operating Instruction and Warranty Terms and acknowledges this by signing the below.

**X**

---

DATE: ...../...../.....



Please email a completed copy to [Warranty@kerfab.com](mailto:Warranty@kerfab.com) within 10 days of receipt of the Cotton Forks

## **KERFAB WARRANTY STATEMENT**

At Kerfab Industries, we take pride in delivering materials handling products that meet and exceed the highest industry standards. Our commitment to quality ensures that our products are engineered to conform to the stringent Australian Standards, providing customers with robust and reliable solutions for their needs. We stand behind the quality of our products and offer the following warranty provisions:

### **Warranty Terms:**

- (1)** Kerfab warrants that our products shall be free from defects in material or workmanship for a period of **24 months** from the date of delivery to the purchasing customer.
- (2)** At our sole discretion, Kerfab may choose to replace or repair the product or any defective part thereof.
- (3)** This warranty is exclusively for the benefit of the named original customer and cannot be transferred or assigned.
- (4)** The warranty applies only to Kerfab products fitted or installed by Kerfab or our approved installers.
- (5)** Travel costs associated with assessing or repairing a Kerfab product covered under this manufacturer's warranty are not included.

### **Customer Responsibilities:**

This warranty is subject to and conditional upon the strict compliance of our customers with the following responsibilities:

- (1)** Customers must notify Kerfab as soon as possible of any claims or circumstances that may give rise to a claim.
- (2)** Customers must provide Kerfab with details of the claim, along with any other information reasonably required to evaluate the claim.
- (3)** The product should not be used once a defect is apparent.
- (4)** It will be the customer's financial responsibility to cover freight to return the attachment / component for assessment. Any claims that are then deemed warrantable the freight cost will be reimbursed.
- (5)** Repairs or attempts to repair the defect by any other party without prior written approval from Kerfab are not allowed.

### **Warranty Exclusions:**

Not everything is covered by this warranty. The following exclusions apply:

- (1)** Mechanical failures due to a failure to comply with the service requirements as specified.
- (2)** Repairs required because of continued operation of the item once a defect or fault has occurred, including the loss of lubricants and coolant that results in consequential damage to associated components or systems.

**(3)** Consequential damage as a result of hydraulic fluid contamination to other components or system related ancillaries. This is not specific to but includes pumps, hoses, fittings, cylinders, valves and reservoirs.

**(4)** Damage resulting from impacts or road traffic accidents.

**(5)** Kerfab Industries are not responsible for any impact to business or financial loss due to the failure of an attachment or component.

This includes but it not limited to:

- personal liability
- work contract or agreement
- revenue or profit
- production
- increase to a business overhead cost

**(6)** Claims where damage to a covered component was caused by a non-covered component.

**(7)** Mechanical failures caused by misuse, neglect, abuse, negligence, lack of normal maintenance, improper servicing, or incorrect operation of the item as per the operations guide as determined by the Kerfab warranty administrator / supervisor.

**(8)** Ground Engaging Tools – Cutting Edge, Bucket Wraps, Teeth, Adapters

**(9)** Chassis and Wearing Components – Bruising on Coupler Chassis, Pins, Bush & Bearing wear, Spring Tensions or components considered a “wear and tear” item.

**(10)** Claims attributable to failure to follow the manufacturer’s operating guidelines or exceeding the manufacturer’s operating limitations.

**(11)** Claims where Kerfab has not been contacted before the commencement of repairs or repairs initiated without a Kerfab-issued work authorization number.

**(12)** Claims where the repair has not been performed by Kerfab, unless specifically authorised by Kerfab before the claim.

**(13)** Mechanical failures arising from unauthorised repairs.

**(14)** Mechanical failures attributed to modifications unless the modification has been endorsed by Kerfab in writing. Modified components must be disclosed in your warranty application and are expressly excluded from coverage.

**(15)** Failures caused by corrosion, electrolysis, fertiliser or rust.

**(16)** Tapping’s, threads, and fixing/fastening devices.

**(17)** Mechanical failures caused by a fault existing before the commencement of coverage.

**(18)** Use of the product for a purpose not specifically designed or intended by the manufacturer.

At Kerfab Industries, we are dedicated to providing you, with high-quality load handling products and support. This warranty statement reflects our commitment to ensuring your satisfaction and peace of mind from our dedicated aftersales team.