

Operation Manual

High Dump Bucket

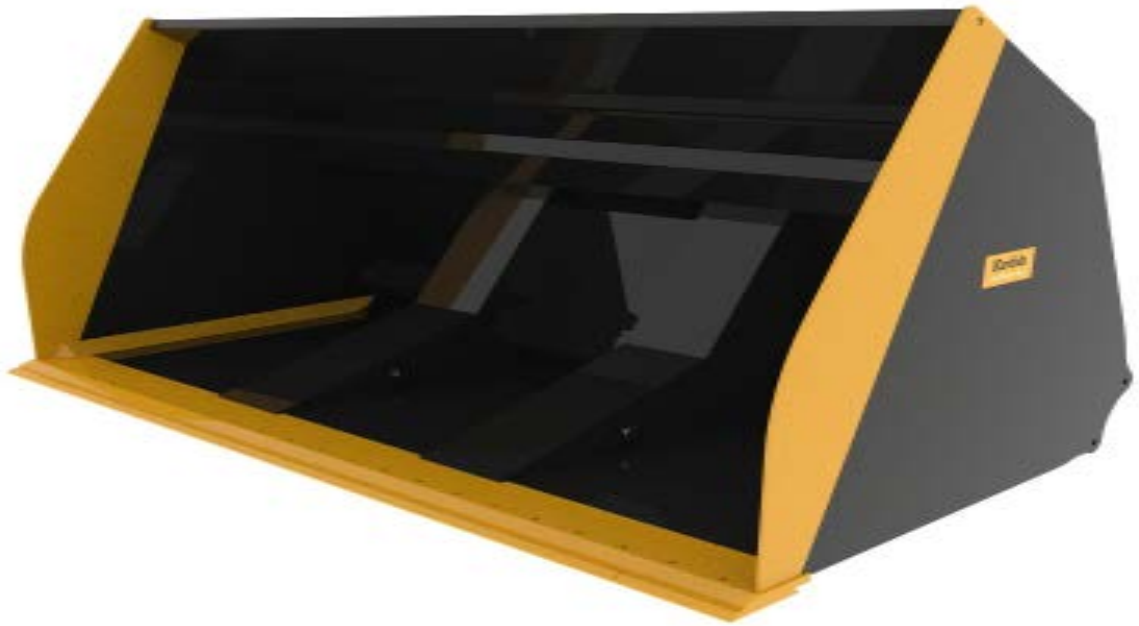

Dear valued customer, we kindly ask that you carefully review the operating manual for your product and complete the product registration process to ensure that you are eligible for warranty coverage. Thank you for taking the time to follow these important steps to protect your investment.



+ 1800 818 079

+ kerfab.com.au

+ sales@kerfab.com

Kerfab
ATTACH+GO

CONTENTS

INTRODUCTION	2
OWNER INFORMATION	2
GENERAL INFORMATION	3
PLANT ASSESSMENT	4
HIGH DUMP BUCKET FEATURES	4
RISK ASSESSMENT AND CONTROL	5
WORKSITE SAFETY	6
MAINTENANCE	6
GREASE POINT DIAGRAM	7
MONTHLY INSPECTION	8
SPARE PARTS	9
OPERATING INSTRUCTIONS	10
HYDRAULIC SUPPLY INSTALLATION INSTRUCTIONS	14
PRODUCT REGISTRATION	15
KERFAB WARRANTY STATEMENT	16





INTRODUCTION

Kerfab is a specialist manufacturer of a comprehensive range of attachments covering a wide spectrum of market sectors. The High Dump Bucket you have purchased is just one of a vast range of purpose-built products available in our range. Each attachment is engineered to relevant codes and standards along with input from experienced team which in turn provides you with an optimum item which will provide you with many years of service.

OWNER INFORMATION

Thank you for choosing to purchase a High Dump Bucket from Kerfab. To ensure maximum performance, it is mandatory that you study this operation manual to ensure your equipment continues to operate to maximum performance. Proper operation and maintenance are essential to prevent injury or damage and to maximise attachment life.

Continuous improvement is at the forefront of the Kerfab culture meaning that changes in product design may not be reflected in this document. Great care has been taken in preparing this document with accuracy however Kerfab does not assume any liability for errors or omissions.

	Potentially Fatal Danger
	Risk of Serious Injury
	Risk of Material Damage and/or Minor Injury
	Maintenance operation or Information

GENERAL INFORMATION

This operation manual was written to provide the owner/ operator instructions on the safe operation and maintenance of the High Dump Bucket Attachment.

PLEASE READ AND UNDERSTAND THE OPERATION AND MAINTENANCE OF YOUR HIGH DUMP BUCKET BEFORE OPERATING YOU KERFAB ATTACHMENT.

Kerfab High Dump Bucket are used on Wheel Loaders, Telehandlers and Agricultural Tractors therefore this manual is a permanent part of your machine.

Attachment Inspection

All delivered products by Kerfab should be initially checked for any defects, damages or missing parts to ensure performance of attachment upon taking delivery of item.



Please notify Kerfab with a report of any problems within 10 business days.

Vital Point

Please keep this manual with the Machine once the attachment has been installed on the machine. The Operator should have a full understanding of full use of this attachment before use.

Attachment Features

The Kerfab High Dump Bucket achieves the highest possible reach, allowing it to easily tip over high sided trucks, fences and othertall obstacles. Multiple options can be fitted to improve suitability for different applications. These include wear plates, internal liners, trash guards and internal coatings. Certain applications require an “outer-pocket” design which moves the rams to the outer edge of the bucket so sticky materials don’t get stuck in corners which is available as an extra.

Plant Assessment

NB. This Plant Assessment ONLY applies to the attachment named below. It DOES NOT extend to other item(s) of plant that are used to operate this attachment

Plant Type:	Hight Dump Bucket
--------------------	--------------------------

Specifications:	Refer to the Identification Plate on the High Dump Bucket for the specifications relevant to this attachment. The loads carried by the High Dump Bucket should NEVER EXCEED THE LOAD LIMIT OF THE BUCKET OR THE LOAD LIMIT OF THE MOBILE PLANT it is attached to eg. wheel loader, telehandler, in the full scope of each mobile plant’s operations.
------------------------	--







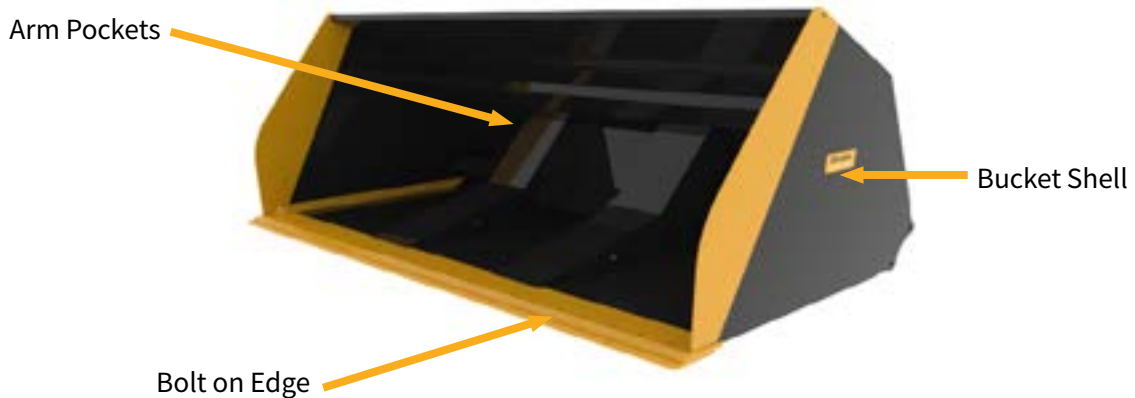







Description of Use:	The High Dump Bucket is designed as an attachment for mobile plant including front end loaders, telehandlers and wheel loaders. It is designed to move and lift material such as sand, dirt, grain, etc. The bucket is designed to tip by pivoting on front hydraulic ram points. NB. DO NOT TIP BUCKET WHILE MOBILE PLANT IS MOVING. ALWAYS STOP MOBILE PLANT BEFORE TIPPING BUCKET
----------------------------	--



High Dump Bucket Features



Risk Assessment and Control







Symbol	Risk	Control
 	Body parts can be crushed between mobile plant and High Dump Bucket mounting frame when connecting High Dump Bucket to mobile plant mount.	Keep hands and body parts clear of area between High Dump Bucket and mobile plant mount.
 	Fingers may be jammed in locking pin points as locking pins are engaged.	Keep fingers clear when engaging locking pins into locking pin points on bucket mounting frame.
 	Hydraulic fluid under pressure may cause injury if released while under pressure.	Ensure all hoses and connectors are in good working condition. Ensure all connections are secured and correctly sealed before using hydraulic controls.
 	Body parts can be crushed if High Dump Bucket unexpectedly releases from mobile plant mount.	Ensure High Dump Bucket is securely attached prior to use including fully engaging locking pins. Regularly check that hitch points on High Dump Bucket and also mount parts are in good condition.
 	Operator or bystanders may be injured by overturning plant if bucket is tipped while mobile plant is moving or when the mobile plant arms are at their full extension.	ALWAYS stop mobile plant before tipping bucket. DONOT tip bucket at the full extension of the mobile plant arms if there is a risk of the mobile plant overbalancing. ALWAYS work within the Manufacture’s working limits for the mobile plant.
 	Body parts can be crushed by unexpected tipping of High Dump Bucket.	Ensure High Dump Bucket is stable when released from mobile plant mount.
 	Hands and body parts can be crushed between the High Dump bucket and the base arms.	Keep body parts clear of bucket when the bucket is in the tipped position. Always store bucket in the fully closed position.

Worksite Safety



- All people involved in the operation are to wear appropriate personal protective equipment which may include eye protection, safety helmets, hearing protection, gloves, protective footwear and high visibility clothing/vests.
- High Dump Bucket should be operated by a trained and experienced operator or an operator under direct supervision.
- People to **NOT** enter work area or sweep area of attachment and load unless under the direction of the operator.
- **DO NOT** tip bucket while mobile plant is moving.
- **DO NOT** tip bucket at the full extension of the mobile plant arms if there is a risk of the mobile plant overbalancing.
- **NEVER** walk under the High Dump Bucket or load.
- **NEVER** elevate High Dump Bucket or load above or in proximity to people.
- **NEVER** elevate High Dump Bucket or load above or in proximity to people.

Maintenance

	Check hitch points and locking pins for wear and damage.	
	Check bucket pivot points and hydraulic ram front and rear pivot points for wear and damage.	
	Check all welds for damage or cracks.	
	Check bucket shell and for excessive wear, damage or rust.	
	Check hydraulic hoses, ram seals and connections for wear, damage or leaks.	
	CAUTION - Always fully secure and support bucket using recognised lifting practices if working on the High Dump bucket to ensure the bucket cannot move or the bucket cannot inadvertently drop if in the tipped position.	

DO NOT USE HIGH DUMP IF WEAR OR DAMAGE MAKES THE USE OF THE HIGH DUMP HAZARDOUS

GREASE POINT DIAGRAM

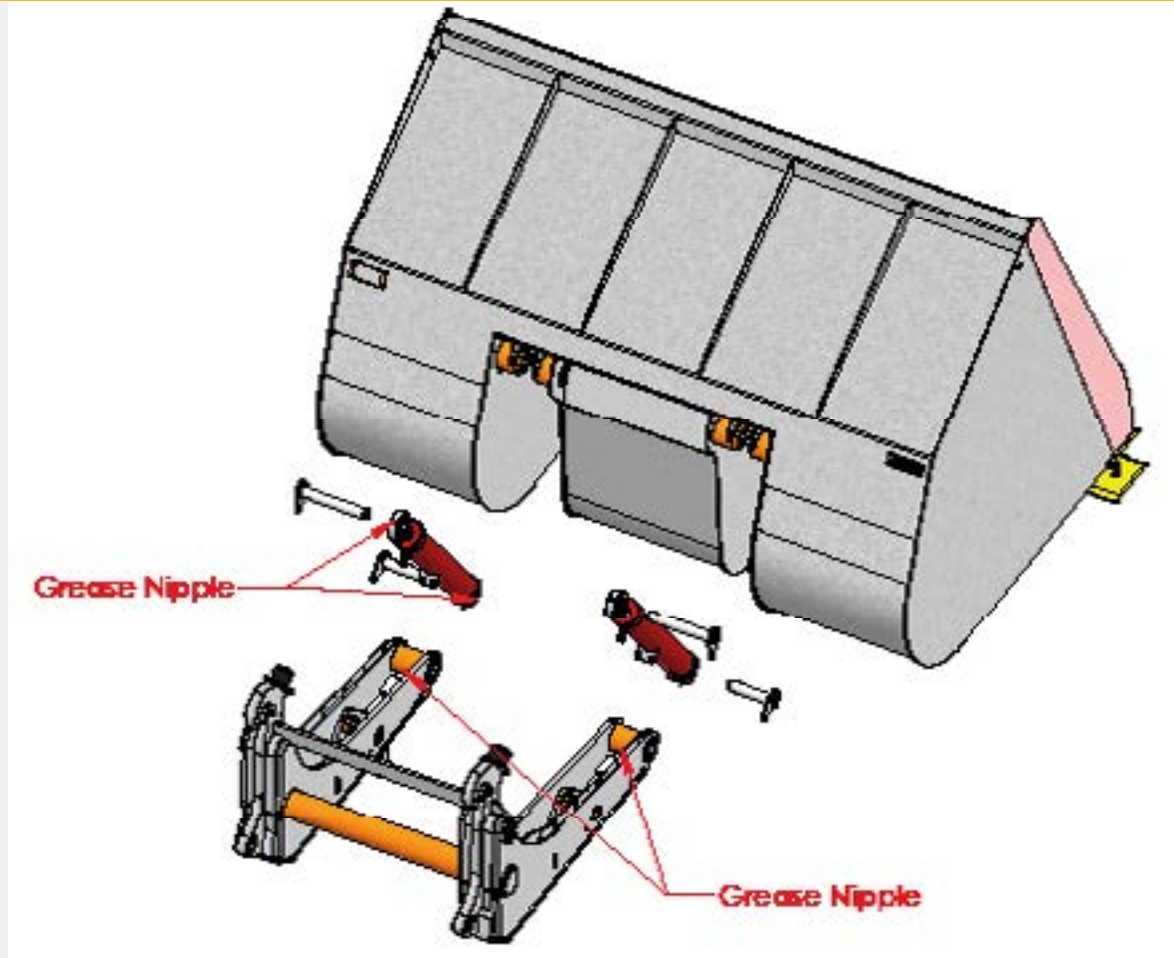

- Ensure the unit is greased via grease nipples as shown.
- Ensure that the attachment is greased every 12Hr of use



MONTHLY INSPECTION

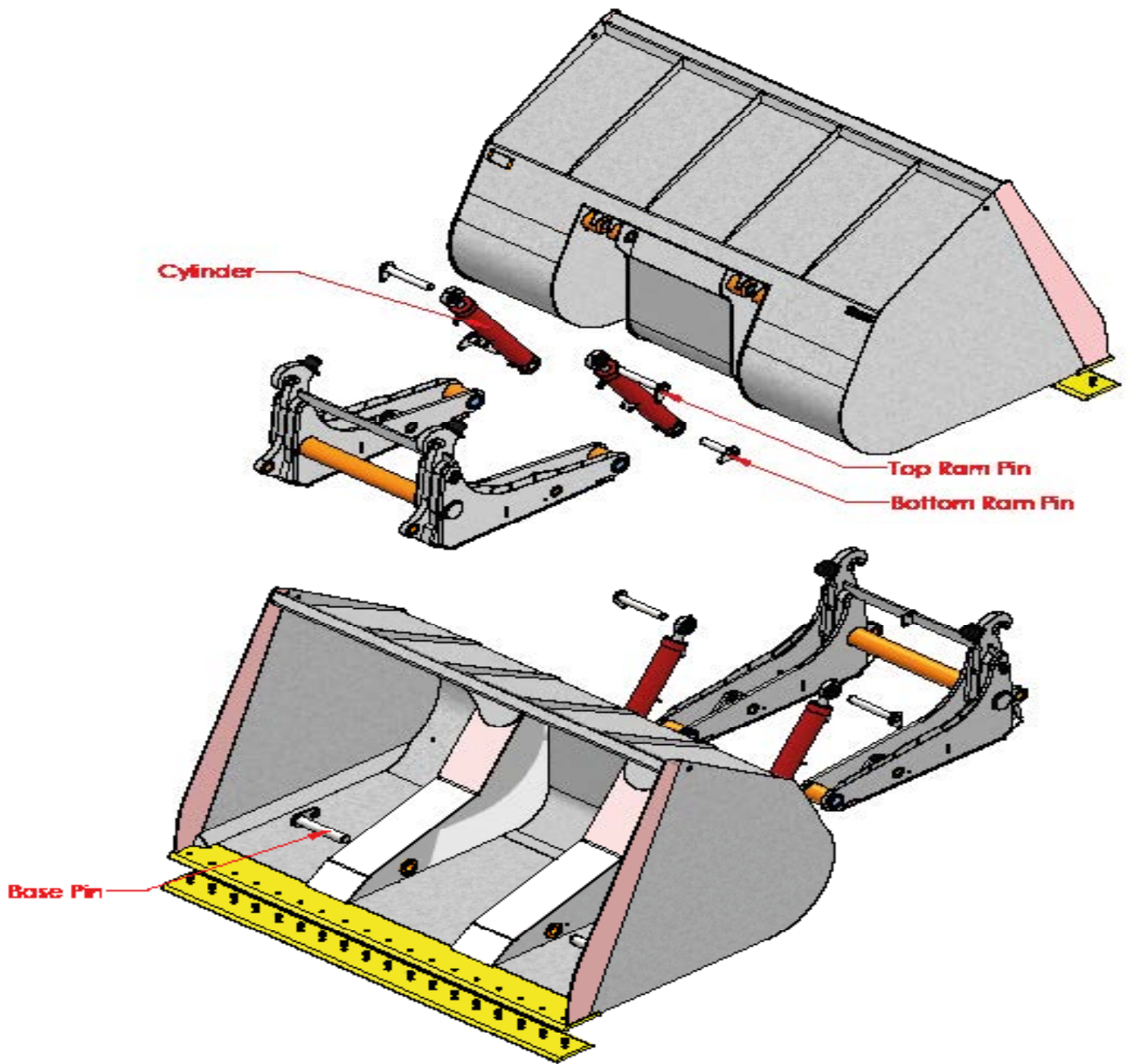

1. Inspect cylinder and hoses for wear and are free from hydraulic oil leaks.
2. Inspect cylinder pins for wear.
3. Inspect frame runners for wear or distortion
4. Check all welds for damage or cracks

SPARE PARTS

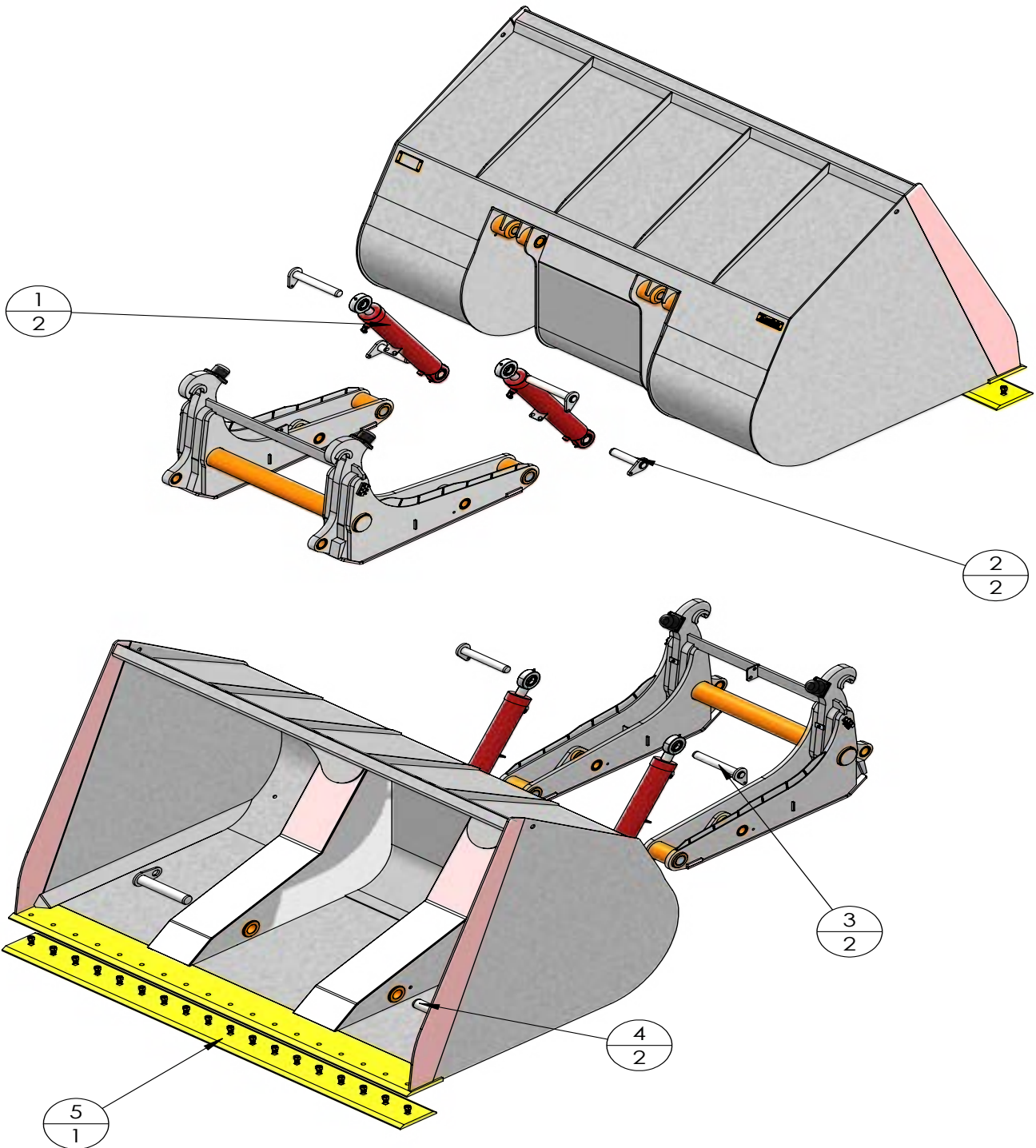

NO.	DESCRIPTION	QTY
1	CYLINDER	2
2	PIN ASSY	2
3	PIN ASSY	2
4	PIN ASSY	2
5	BOLT ON EDGE (COMES WITH HARDWARE)	1

OPERATING INSTRUCTIONS

ENGAGING IMPLEMENT STEPS

STEP 1

Approach High Dump Bucket with top pick-up bar in sight and aligned with quick hitch hooks.

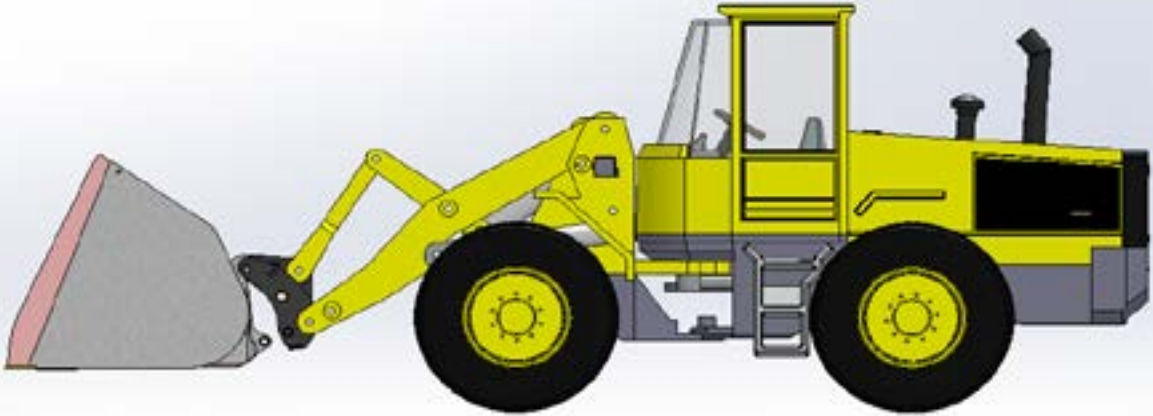
**STEP 2**

Engage top bar with hook by raising loader arms. Roll High Dump Bucket back to ensure hook stopper is resting against the coupler. Engage quick coupler locking pins.

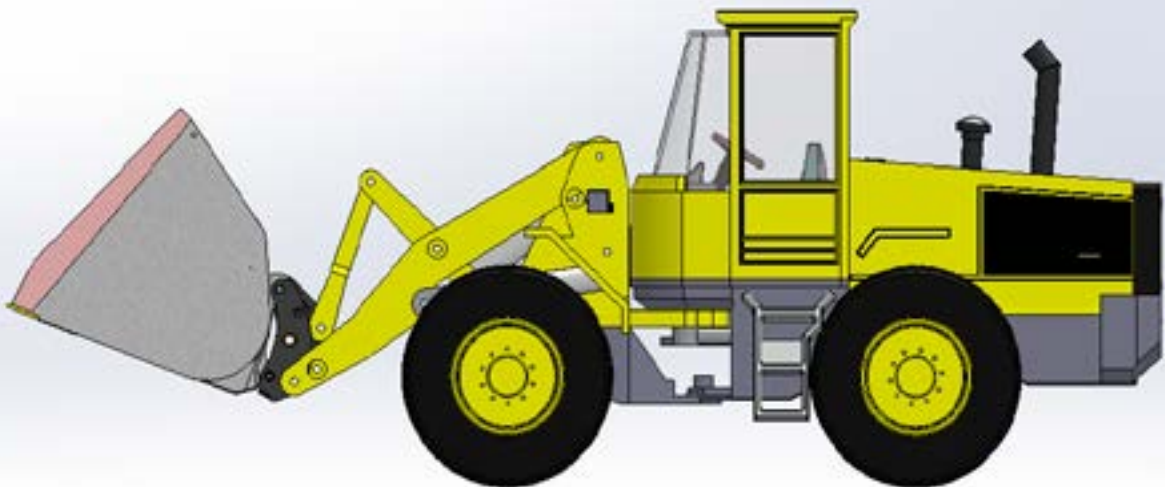

STEP 3

Check that locking pins are engaged by view indicators. Note: Models with no indicators will require a physical check by the operator

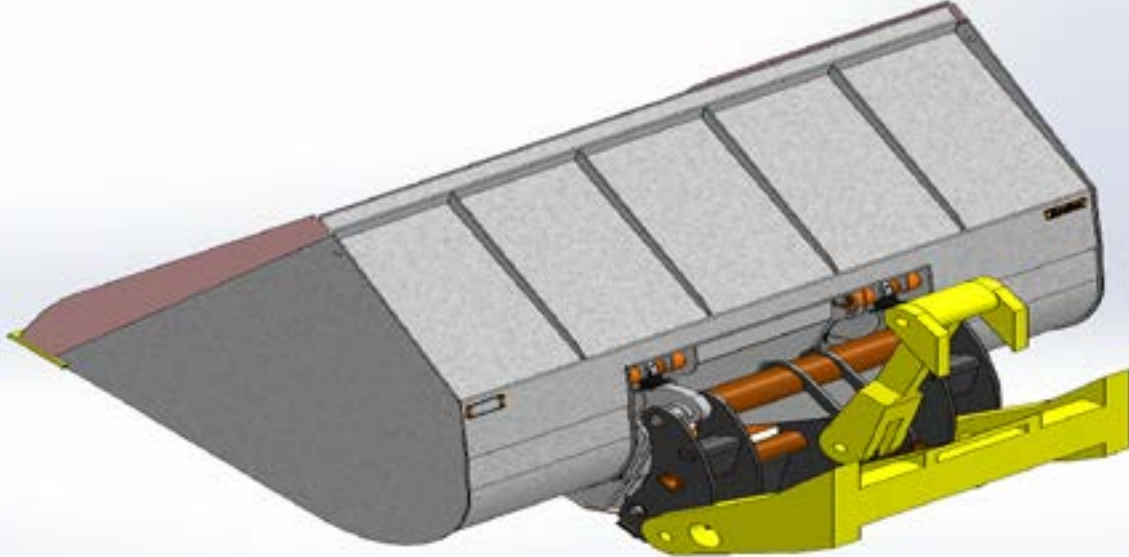
**DISENGAGING IMPLEMENT STEPS****STEP 1**

Slightly roll back implement to ensure hook bump stops are resting against the quick coupler. Disengage locking pins.

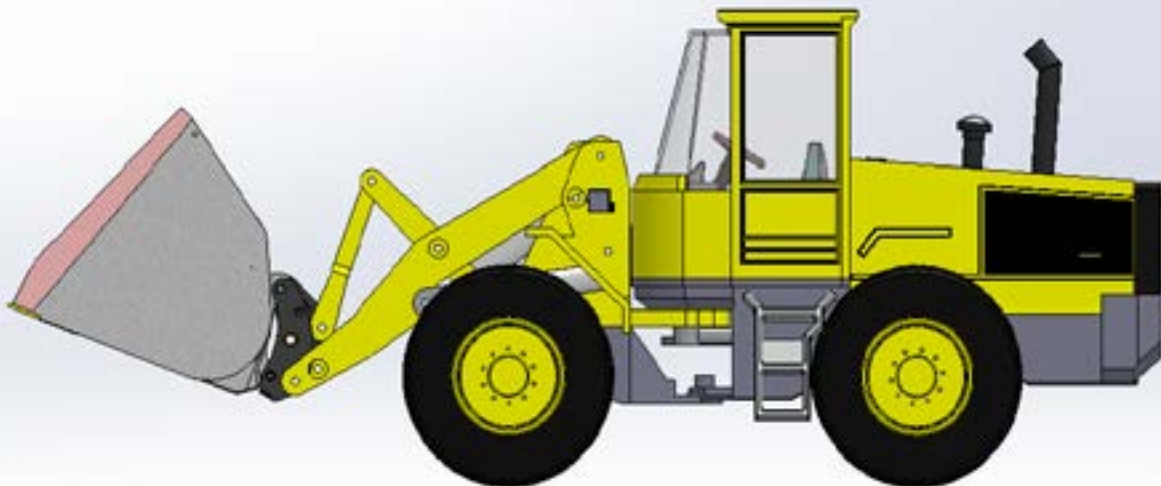

STEP 2

Check that locking pins are disengaged. Note: Models without indicators may need a physical check by the operator.

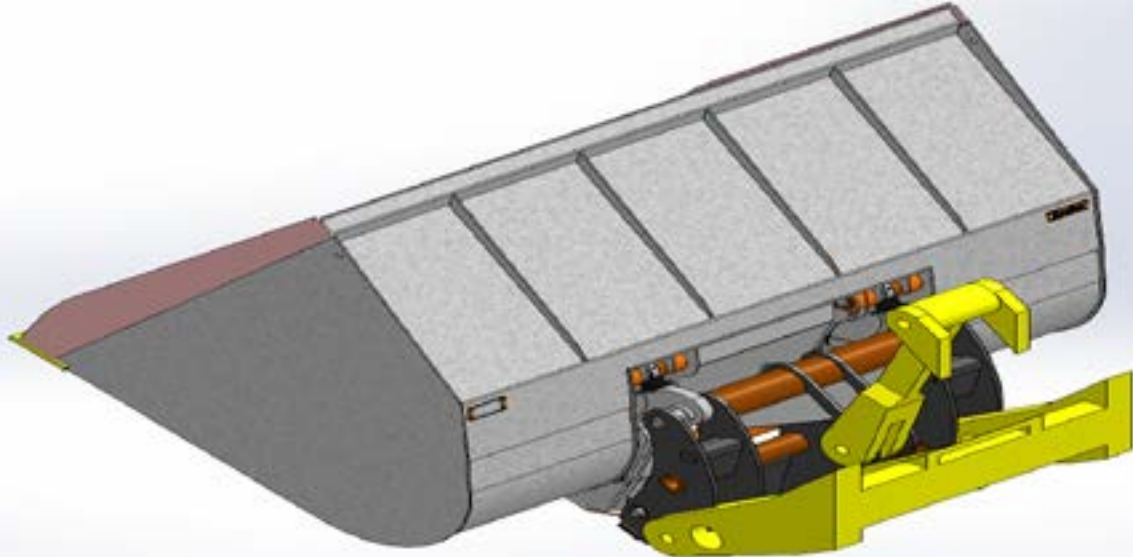
**STEP 3**

Slightly roll coupler forward to rest front of High Dump Bucket on the ground as shown.

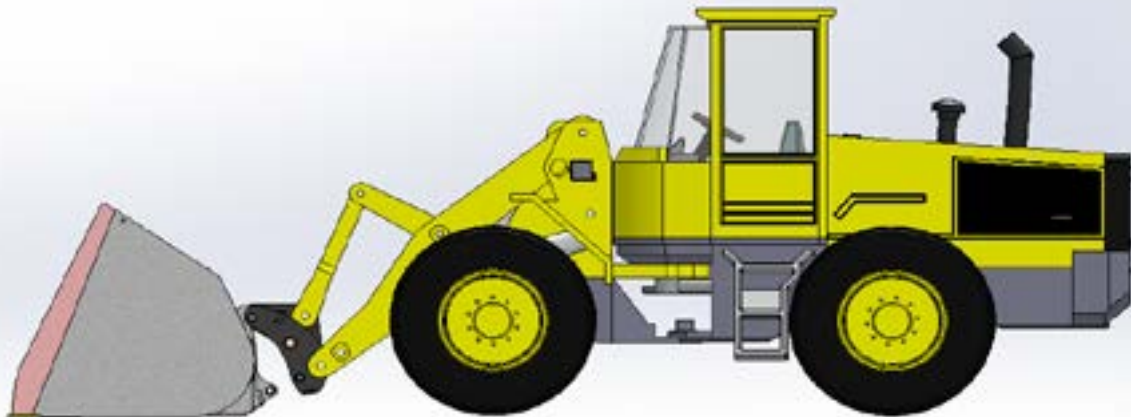

STEP 4

Lower loader arms until top pick-up bar becomes disengaged from quick coupler hooks

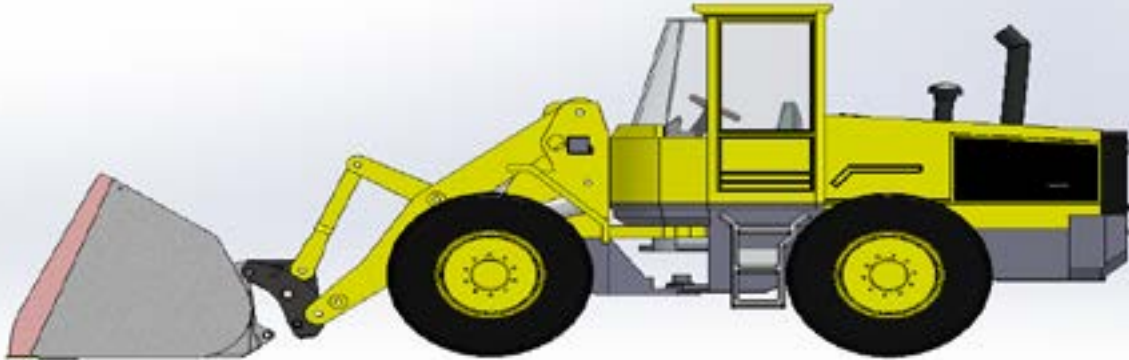

WARNING: NEVER ROLL COUPLER OVER AS SHOWN BEFORE DISENGAGING. *This will cause damage to attachment*

**STEP 5**

Reverse away from High Dump Bucket.

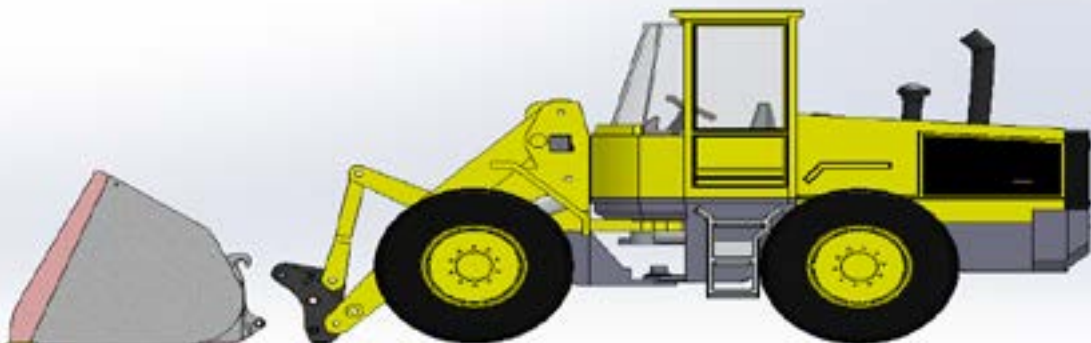

HYDRAULIC SUPPLY INSTALLATION INSTRUCTIONS

1. Each High Dump Bucket comes with provisions to connect the hydraulic supply.
2. Connect hoses from High Dump Bucket to the machine. Ensure all hoses are tight and routed correctly to ensure hoses are not damaged while the implement is in use.



Product Registration

Date of Delivery:	
Name:	
Company:	
Street Address:	
Phone Number:	
E-mail Address:	
Model Number:	
Serial Number:	
Sales Order Number:	

I confirm that the operator has read and understands the Operating Instruction and Warranty Terms and acknowledges this by signing the below.

X

DATE:/...../.....



Please email a completed copy to warranty@kerfab.com within 10 days of receipt of the High Dump Bucket.

KERFAB WARRANTY STATEMENT

At Kerfab Industries, we take pride in delivering materials handling products that meet and exceed the highest industry standards. Our commitment to quality ensures that our products are engineered to conform to the stringent Australian Standards, providing customers with robust and reliable solutions for their needs. We stand behind the quality of our products and offer the following warranty provisions:

Warranty Terms:

- (1)** Kerfab warrants that our products shall be free from defects in material or workmanship for a period of **24 months** from the date of delivery to the purchasing customer.
- (2)** At our sole discretion, Kerfab may choose to replace or repair the product or any defective part thereof.
- (3)** This warranty is exclusively for the benefit of the named original customer and cannot be transferred or assigned.
- (4)** The warranty applies only to Kerfab products fitted or installed by Kerfab or our approved installers.
- (5)** Travel costs associated with assessing or repairing a Kerfab product covered under this manufacturer's warranty are not included.

Customer Responsibilities:

This warranty is subject to and conditional upon the strict compliance of our customers with the following responsibilities:

- (1)** Customers must notify Kerfab as soon as possible of any claims or circumstances that may give rise to a claim.
- (2)** Customers must provide Kerfab with details of the claim, along with any other information reasonably required to evaluate the claim.
- (3)** The product should not be used once a defect is apparent.
- (4)** It will be the customers financial responsibility to cover freight to return the attachment / component for assessment. Any claims that are then deemed warrantable the freight cost will be reimbursed.
- (5)** Repairs or attempts to repair the defect by any other party without prior written approval from Kerfab are not allowed.

Warranty Exclusions:

Not everything is covered by this warranty. The following exclusions apply:

- (1)** Mechanical failures due to a failure to comply with the service requirements as specified.
- (2)** Repairs required because of continued operation of the item once a defect or fault has occurred, including the loss of lubricants and coolant that results in consequential damage to associated components or systems.

(3) Consequential damage as a result of hydraulic fluid contamination to other components or system related ancillaries. This is not specific to but includes pumps, hoses, fittings, cylinders, valves and reservoirs.

(4) Damage resulting from impacts or road traffic accidents.

(5) Kerfab Industries are not responsible for any impact to business or financial loss due to the failure of an attachment or component.

This includes but it not limited to:

- personal liability
- work contract or agreement
- revenue or profit
- production
- increase to a business overhead cost

(6) Claims where damage to a covered component was caused by a non-covered component.

(7) Mechanical failures caused by misuse, neglect, abuse, negligence, lack of normal maintenance, improper servicing, or incorrect operation of the item as per the operations guide as determined by the Kerfab warranty administrator / supervisor.

(8) Ground Engaging Tools – Cutting Edge, Bucket Wraps, Teeth, Adapters

(9) Chassis and Wearing Components – Bruising on Coupler Chassis, Pins, Bush & Bearing wear, Spring Tensions or components considered a “wear and tear” item.

(10) Claims attributable to failure to follow the manufacturer’s operating guidelines or exceeding the manufacturer’s operating limitations.

(11) Claims where Kerfab has not been contacted before the commencement of repairs or repairs initiated without a Kerfab-issued work authorization number.

(12) Claims where the repair has not been performed by Kerfab, unless specifically authorised by Kerfab before the claim.

(13) Mechanical failures arising from unauthorised repairs.

(14) Mechanical failures attributed to modifications unless the modification has been endorsed by Kerfab in writing. Modified components must be disclosed in your warranty application and are expressly excluded from coverage.

(15) Failures caused by corrosion, electrolysis, fertiliser or rust.

(16) Tapping’s, threads, and fixing/fastening devices.

(17) Mechanical failures caused by a fault existing before the commencement of coverage.

(18) Use of the product for a purpose not specifically designed or intended by the manufacturer.

At Kerfab Industries, we are dedicated to providing you, with high-quality load handling products and support. This warranty statement reflects our commitment to ensuring your satisfaction and peace of mind from our dedicated aftersales team.